

SS256TC20M-2

WASHDOWN DUTY MOTOR
 HIGH EFFICIENCY / EISA COMPLIANT
 STAINLESS STEEL CONSTRUCTION - C-FLANGE WITH FEET
 TOTALLY ENCLOSED FAN COOLED - IP66 CONSTRUCTION
 INVERTER DUTY 10:1 CT; 20:1 VT - NEMA MG1 PART 31

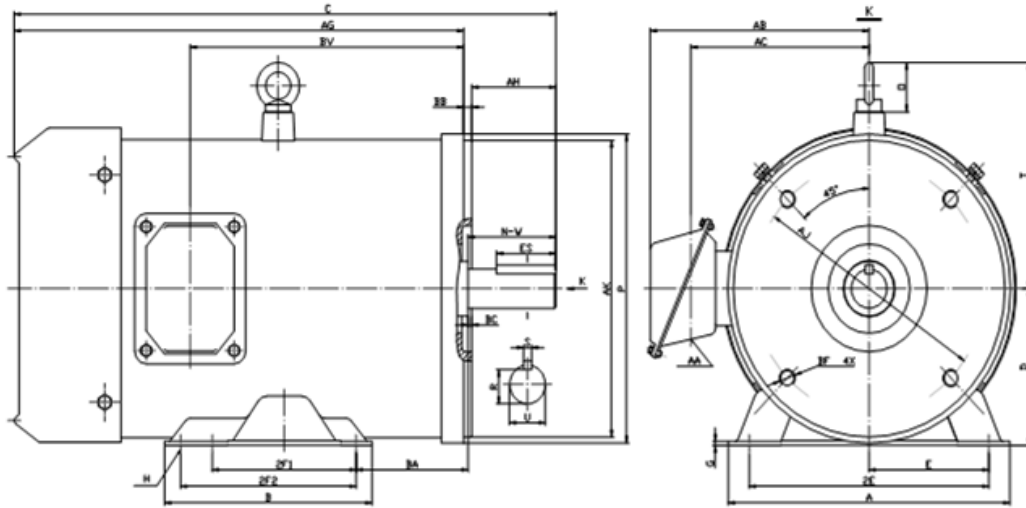

DIMENSIONS

HP	RPM	Frame	Mounting													
			A	B	C	D	G	H	E	2E	2F1	2F2	P	AK	AJ	AH
20	3600	256TC	11.20	11.25	24.80	6.25	0.47	0.53	5.00	10.00	0.00	10.00	11.72	8.500	7.250	3.75

Mounting					Shaft Extension, Key Set					Conduit Box				Bearings		Mount
AG	BA	BB	BC	BF	U	R	S	ES	N-W	AA	AB	AC	BV	DE	ODE	
20.80	4.75	0.25	0.25	4*3/8-16	1.625	1.416	0.375	2.91	4.00	1.00	9.50	7.80	14.10	6309	6309	F1

BEARING LUBRICATION: The bearings come lubricated with Mobile Polyrex EM Polyurea Grease.



Murphey Electric LLC

Serving Industry With The Best Products And Service Since 1928

411 Platte Ave.
 York, NE. 68467

Phone: 402-362-3245
 Toll Free / Fax: 888-226-4917



SS256TC20M-2

WASHDOWN DUTY MOTOR
HIGH EFFICIENCY / EISA COMPLIANT
STAINLESS STEEL CONSTRUCTION - C-FLANGE WITH FEET
TOTALLY ENCLOSED FAN COOLED - IP66 CONSTRUCTION
INVERTER DUTY 10:1 CT; 20:1 VT - NEMA MG1 PART 31

PERFORMANCE DATA

HP	RPM	Frame	Voltage	Frequency (Hz)	Full Load S.F.	Insulation Class	NEMA Design	Slip (%)	NEMA Code	Enclosure Type	IP Rating	Max. Ambient
20	3540	256TC	208-230/460	60	1.15	F	C	1.7	G	TEFC	66	40° C

Amps (460V)		Efficiency (%)				Power Factor			Torque (ft-lb)			DE Bearing	ODE Bearing	Connection	Weight (lbs.)
FLA	LRA	100%	75%	50%	Min.	100%	75%	50%	FLT	LRT %	BDT %	6309	6309	12 Lead 2Δ/Δ	422
23.0	145.0	91.0	90.5	90.0	89.5	0.90	0.85	0.76	29.3	200	250				

NAME PLATE

		WASHDOWN DUTY STAINLESS STEEL MOTOR				CONNECTION DIAGRAMS	
INVERTER DUTY 20:1 VT; 10:1 CT				HIGH EFFICIENCY EISA COMPLIANT			
CAT NO: SS256TC20M-2		FRAME 256TC		PHASE 3			
HZ 60	S.F. 1.15	HZ 50	S.F. 1.2	ENCL TEFC	IP 66		
HP 20	RPM 3540	HP 15	RPM 2935	DUTY CONT	DES C		
VOLTS 208-230/460		VOLTS 190/380		AMB 40° C	INS F		
FLA 50.9 - 46 / 23	FLA 42/21		DE BEARING 6309				
CODE G	P.F. 0.90	CODE G	P.F. 0.91	ODE BEARING 6309			
EFF 91.0	MIN 89.5	EFF 89.5	MIN 87.5	LUB: Mobile Polyrex EM			
MOTOR WEIGHT 422 LBS	CONNECTION 12 Lead 2Δ/Δ		SER NO				
Special purpose motor designed for washdown applications and extremely corrosive environments. Hernando, Mississippi						CC 082A	

APPLICATIONS:

Applications include washdown applications, food processing, chemical processing, pharmaceuticals, poultry processing, meat processing, dairy applications, bakeries, snack foods, bottling and extremely corrosive environments.



Murphey Electric LLC
 Serving Industry With The Best Products And Service Since 1928

411 Platte Ave.
 York, NE. 68467

Phone: 402-362-3245
 Toll Free / Fax: 888-226-4917