

SS184TC5M-4

WASHDOWN DUTY MOTOR
 HIGH EFFICIENCY / EISA COMPLIANT
 STAINLESS STEEL CONSTRUCTION - C-FLANGE WITH FEET
 TOTALLY ENCLOSED FAN COOLED - IP66 CONSTRUCTION
 INVERTER DUTY 10:1 CT; 20:1 VT - NEMA MG1 PART 31

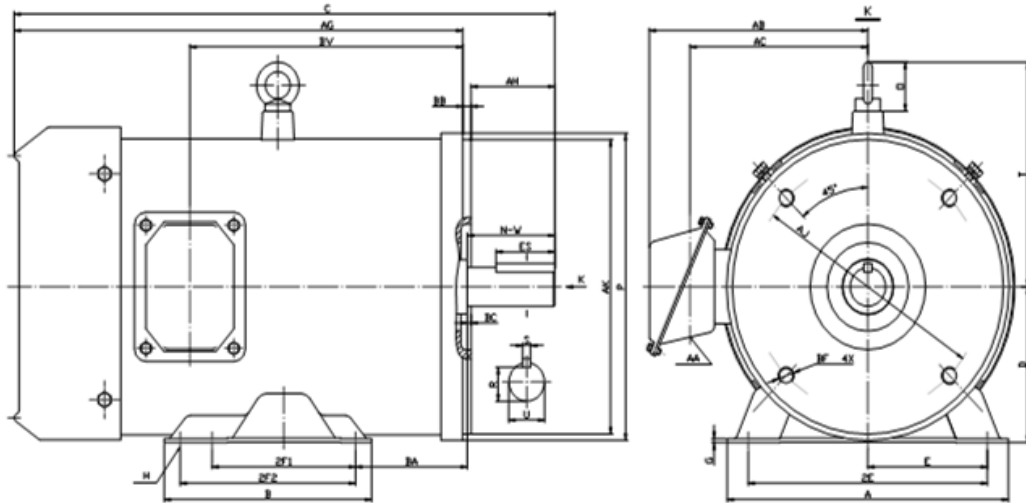

DIMENSIONS

| HP | RPM | Frame | Mounting | | | | | | | | | | | | | |
|----|------|-------|----------|------|-------|------|------|-----------|------|------|------|------|------|-------|-------|------|
| | | | A | B | C | D | G | H | E | 2E | 2F1 | 2F2 | P | AK | AJ | AH |
| 5 | 1800 | 184TC | 8.80 | 6.50 | 17.00 | 4.50 | 0.12 | 0.71*0.47 | 3.75 | 7.50 | 4.50 | 5.50 | 8.85 | 8.500 | 7.250 | 2.62 |

| Mounting | | | | | Shaft Extension, Key Set | | | | | Conduit Box | | | | Bearings | | Mount |
|----------|------|------|------|----------|--------------------------|-------|-------|------|------|-------------|------|------|------|----------|------|-------|
| AG | BA | BB | BC | BF | U | R | S | ES | N-W | AA | AB | AC | BV | DE | ODE | |
| 14.13 | 3.50 | 0.25 | 0.12 | 4*3/8-16 | 1.125 | 0.986 | 0.250 | 1.78 | 2.75 | 0.94 | 7.00 | 5.30 | 8.60 | 6308 | 6306 | F1 |

BEARING LUBRICATION: The bearings come lubricated with Mobile Polyrex EM Polyurea Grease.



Murphey Electric LLC

Serving Industry With The Best Products And Service Since 1928

411 Platte Ave.
 York, NE. 68467

Phone: 402-362-3245
 Toll Free / Fax: 888-226-4917



SS184TC5M-4

WASHDOWN DUTY MOTOR
HIGH EFFICIENCY / EISA COMPLIANT
STAINLESS STEEL CONSTRUCTION - C-FLANGE WITH FEET
TOTALLY ENCLOSED FAN COOLED - IP66 CONSTRUCTION
INVERTER DUTY 10:1 CT; 20:1 VT - NEMA MG1 PART 31

PERFORMANCE DATA

| HP | RPM | Frame | Voltage | Frequency (Hz) | Full Load S.F. | Insulation Class | NEMA Design | Slip (%) | NEMA Code | Enclosure Type | IP Rating | Max. Ambient |
|----|------|-------|-------------|----------------|----------------|------------------|-------------|----------|-----------|----------------|-----------|--------------|
| 5 | 1765 | 184TC | 208-230/460 | 60 | 1.15 | F | C | 1.9 | J | TEFC | 66 | 40° C |

| Amps (460V) | | Efficiency (%) | | | | Power Factor | | | Torque (ft-lb) | | | DE Bearing | ODE Bearing | Connection | Weight (lbs.) |
|-------------|------|----------------|------|------|------|--------------|------|------|----------------|-------|-------|------------|-------------|-------------|---------------|
| FLA | LRA | 100% | 75% | 50% | Min. | 100% | 75% | 50% | FLT | LRT % | BDT % | 6308 | 6306 | 9 Lead 2Y/Y | 100 |
| 6.3 | 46.0 | 89.5 | 90.0 | 89.0 | 87.5 | 0.85 | 0.77 | 0.66 | 14.7 | 255 | 280 | | | | |

NAME PLATE

| | | | | | | | |
|---|------------------------|--|-----------------|---------------------------------------|-------|----------------------------|--|
| | | WASHDOWN DUTY STAINLESS STEEL MOTOR | | | | CONNECTION DIAGRAMS | |
| INVERTER DUTY 20:1 VT; 10:1 CT | | | | HIGH EFFICIENCY EISA COMPLIANT | | | |
| CAT NO: SS184TC5M-4 | | FRAME 184TC | | PHASE 3 | | | |
| HZ 60 | S.F. 1.15 | HZ 50 | S.F. 1.2 | ENCL TEFC | IP 66 | | |
| HP 5 | RPM 1765 | HP 3 | RPM 1460 | DUTY CONT | DES C | | |
| VOLTS 208-230/460 | | VOLTS 190/380 | | AMB 40° C | INS F | | |
| FLA 13.8 - 12.5 / 6.25 | FLA 9/4.5 | | DE BEARING 6308 | | | | |
| CODE J | P.F. 0.85 | CODE K | P.F. 0.88 | ODE BEARING 6306 | | | |
| EFF 89.5 | MIN 87.5 | EFF 87.5 | MIN 85.5 | LUB: Mobile Polyrex EM | | | |
| MOTOR WEIGHT 100 LBS | CONNECTION 9 Lead 2Y/Y | | SER NO | | | | |
| Special purpose motor designed for washdown applications and extremely corrosive environments. Hernando, Mississippi | | | | | | CC 082A | |

APPLICATIONS:

Applications include washdown applications, food processing, chemical processing, pharmaceuticals, poultry processing, meat processing, dairy applications, bakeries, snack foods, bottling and extremely corrosive environments.



Murphey Electric LLC

Serving Industry With The Best Products And Service Since 1928

411 Platte Ave.
York, NE. 68467

Phone: 402-362-3245
Toll Free / Fax: 888-226-4917