

PEXP213T-7.5-2

Premium Efficient Explosion Proof Motor

Class I, Division I, Groups C & D and Class II, Division I, Groups E, F and G - Operating Temperature Code: T3C

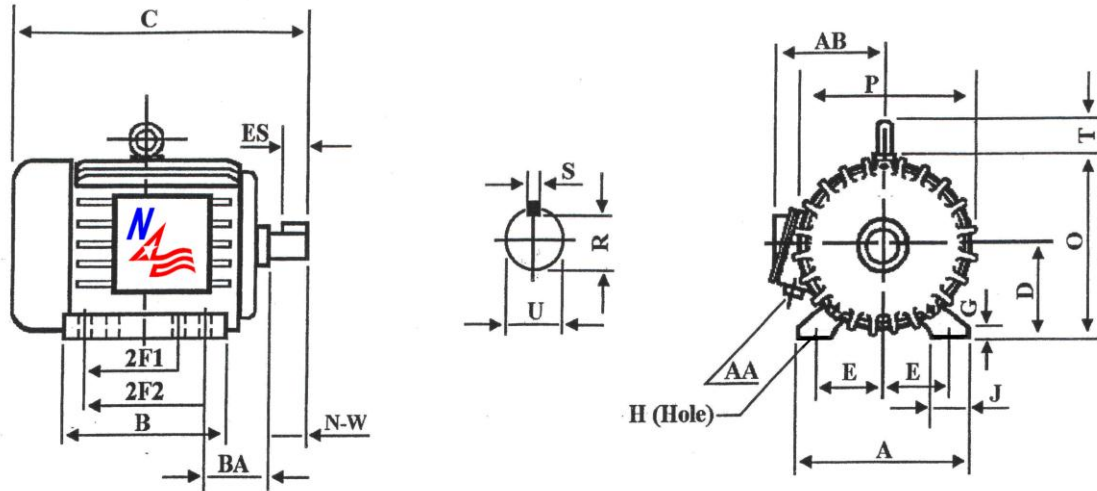

DIMENSIONS – INCHES

A	B	C	D	E	2F1	2F2	G	H	J	O
10.5	8.7	20.3	5.25	8.5	5.5	7	0.8	0.4	2.4	10.5
P	R	S	T	U	ES	AA	AB	BA	N-W	Mount
11.4	1.201	0.312	2	1.375	2.41	1	10	3.5	3.38	F1

PERFORMANCE DATA

Three Phase – 60Hz - 208-230/460V – NEMA Design B – Max. Ambient: 40° C

HP	Speed	Frame	NEMA Code	Efficiency (%)			Power Factor			Torque (ft-lb)		
				100%	75%	50%	100%	75%	50%	FLT	BDT%	LRT%
7.5	3539	213T	H	89.5	90.2	90.0	86.0	89.7	84.6	11.17	200	140
Amps (460V)		DE Bearing	ODE Bearing	Insulation Class	Enclosure Type	Service Factor	Weight (lbs)					
FLA	LRA											
8.3	63.5	6308-ZZ	6308-ZZ	F	TEFC	1.15	253					



ElectricalHelper

"Practical Straight Forward Electrical Wiring Solutions Since 1928."

For Fast Friendly Assistance
Call Us 888.226.4917
Hours 8:00AM - 5:00PM