

PEXP143T-1.5-2

Premium Efficient Explosion Proof Motor

Class I, Division I, Groups C & D and Class II, Division I, Groups E, F and G - Operating Temperature Code: T3C

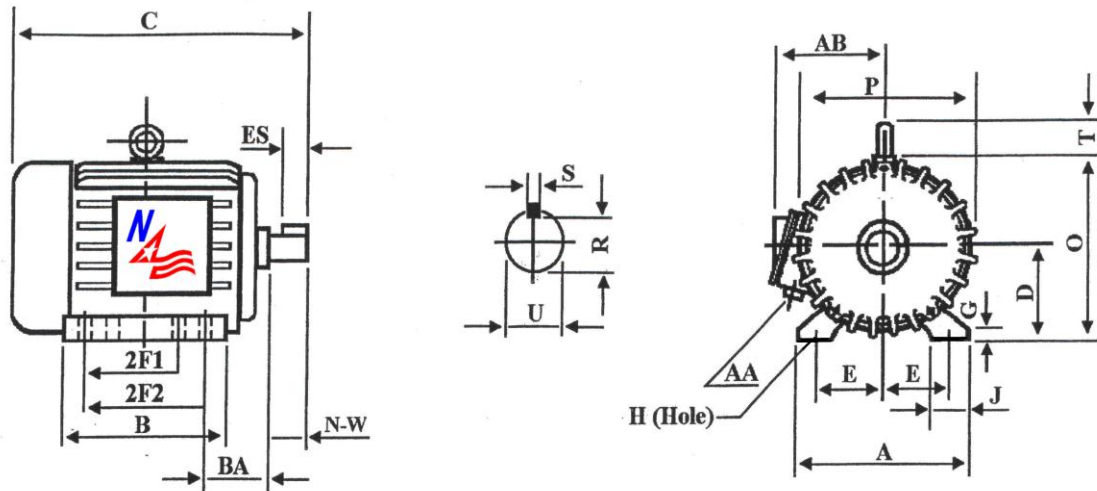

DIMENSIONS – INCHES

| A | B | C | D | E | 2F1 | 2F2 | G | H | J | O |
|-----|-------|-------|-----|-------|------|------|-----|------|------|-------|
| 7 | 6.9 | 14.6 | 3.5 | 5.5 | 4 | 5 | 0.5 | 0.3 | 1.4 | 7.6 |
| P | R | S | T | U | ES | AA | AB | BA | N-W | Mount |
| 7.5 | 0.771 | 0.188 | 1.6 | 0.875 | 1.41 | 0.75 | 6.9 | 2.25 | 2.25 | F1 |

PERFORMANCE DATA

Three Phase – 60Hz - 208-230/460V – NEMA Design B – Max. Ambient: 40° C

| HP | Speed | Frame | NEMA Code | Efficiency (%) | | | Power Factor | | | Torque (ft-lb) | | |
|--------------|-------|------------|-------------|------------------|----------------|----------------|--------------|------|------|----------------|------|------|
| | | | | 100% | 75% | 50% | 100% | 75% | 50% | FLT | BDT% | LRT% |
| 1.5 | 3511 | 143T | K | 82.5 | 86.2 | 85.1 | 84.5 | 81.3 | 68.6 | 2.3 | 250 | 175 |
| Amps (460V) | | DE Bearing | ODE Bearing | Insulation Class | Enclosure Type | Service Factor | Weight (lbs) | | | | | |
| FLA | LRA | | | | | | | | | | | |
| 1.9 | 20 | 6205-ZZ | 6205-ZZ | F | TEFC | 1.15 | 73 | | | | | |



ElectricalHelper

"Practical Straight Forward Electrical Wiring Solutions Since 1928."

For Fast Friendly Assistance
Call Us 888.226.4917
Hours 8:00AM - 5:00PM