

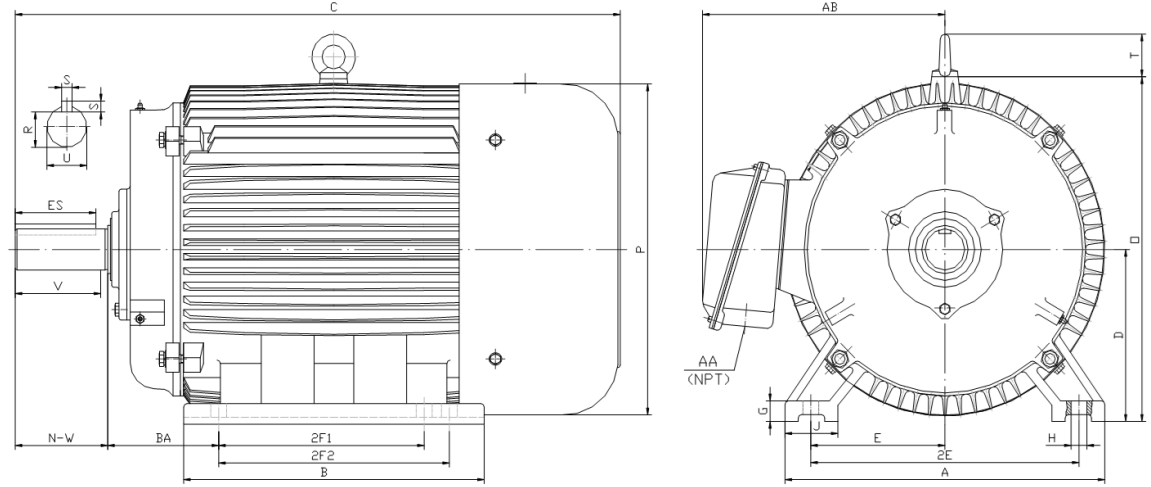

PE143T-1-4

GENERAL PURPOSE ELECTRIC MOTOR
NEMA PREMIUM EFFICIENCY
TOTALLY ENCLOSED FAN COOLED
INVERTER DUTY 10:1 CT; 20:1 VT - NEMA MG1 PART 31
 Factory Certified for T2B Class I, Division II, Groups A,B,C & D and Class II, Division II, Groups F & G



DIMENSIONS

HP	RPM	Frame	MOUNTING														
			A	B	C	D	G	H	J	E	2E	2F1	2F2	O	P	T	BA
1	1800	143T	7.00	5.20	13.60	3.50	0.50	0.34	1.40	2.75	5.50	4.00	5.00	7.10	6.95	0.00	2.25

Shaft Extension, Key Set						Conduit Box		Bearings		Mount
U	V	R	S	ES	N-W	AA	AB	DE	ODE	
0.875	2.00	0.771	0.188	1.41	2.25	0.75	6.10	6205-ZZ	6205-ZZ	F1

BEARING LUBRICATION: The bearings come lubricated with Mobil Polyrex EM Polyurea Grease.



ElectricalHelper.org
 For All Your Electric Needs Since 1928
 411 N Platte Ave. York, NE. 68467

AC-DC MOTORS :: SALES & SERVICE
REWINDING :: CUSTOM CONTROL PANEL

Kelly MacMillan
 Office PH: 888.226.4917 Ext. 102
 Fax: 888.226.4917
 Cell: 402.679.1579
 E-Mail: kelly@electricalhelper.com



PE143T-1-4

GENERAL PURPOSE ELECTRIC MOTOR

NEMA PREMIUM EFFICIENCY

TOTALLY ENCLOSED FAN COOLED

INVERTER DUTY 10:1 CT; 20:1 VT - NEMA MG1 PART 31

Factory Certified for T2B Class I, Division II, Groups A,B,C & D and Class II, Division II, Groups F & G

PERFORMANCE DATA

HP	RPM	Frame	Voltage	Frequency (Hz)	Full Load S.F.	Insulation Class	NEMA Design	Slip (%)	NEMA Code	Enclosure Type	IP Rating	Max. Ambient
1	1745	143T	208-230/460	60	1.15	F	B	3.1	M	TEFC	55	40° C

Amps (460V)		Efficiency (%)				Power Factor			Torque (ft-lb)			DE Bearing	ODE Bearing	Connection	Weight (lbs.)
FLA	LRA	100%	75%	50%	Min.	100%	75%	50%	FLT	LRT %	BDT %				
1.5	15	85.5	85.0	83.6	82.5	0.710	0.620	0.490	3.0	275	310	6205-ZZ	6205-ZZ	9 Lead 2Y/Y	47

NAME PLATE

<p>INVERTER DUTY 20:1 VT; 10:1 CT</p>										CONNECTION DIAGRAMS		
CAT NO: PE143T-1-4			FRAME 143T			PHASE 3				<p>208-230V</p>		
HZ 60	S.F. 1.15	HZ 50	S.F. 1.0	ENCL TEFC	IP 55							
HP 1	RPM 1745	HP 1	RPM 1430	DUTY CONT	DES B	<p>460V</p>						
VOLTS 208-230/460		VOLTS 190/380		AMB 40° C	INS F							
FLA 3.2 - 3 / 1.5		FLA 3.6/1.8		DE BEARING 6205-ZZ								
CODE M	P.F. 0.71	CODE H	P.F. 0.77	ODE BEARING 6205-ZZ								
EFF 85.5	MIN 82.5	EFF 83	MIN 80	LUB: Mobil Polyrex EM								
MOTOR WEIGHT 47 LBS		CONNECTION 9 Lead 2Y/Y		SER NO								
<p>General purpose use on industrial machinery installed in damp, dusty or dirty environments.</p> <p>CC 082A</p>												

APPLICATIONS:

General purpose use on pumps, fans, blowers, compressors, conveyors, material handling and other industrial machinery installed in damp, dusty or dirty environments.



ElectricalHelper.org

For All Your Electric Needs Since 1928
411 N Platte Ave. York, NE. 68467

AC-DC MOTORS :: SALES & SERVICE
REWINDING :: CUSTOM CONTROL PANEL

Kelly MacMillan

Office PH: 888.226.4917 Ext. 102

Fax: 888.226.4917

Cell: 402.679.1579

E-Mail: kelly@electricalhelper.com