

### F56C3/4M2D

GENERAL PURPOSE ELECTRIC MOTOR  
 HIGH EFFICIENCY / EISA COMPLIANT  
 TOTALLY ENCLOSED FAN COOLED  
 ROLLED STEEL CONSTRUCTION  
 INVERTER RATED (10:1 VT; 5:1 CT)

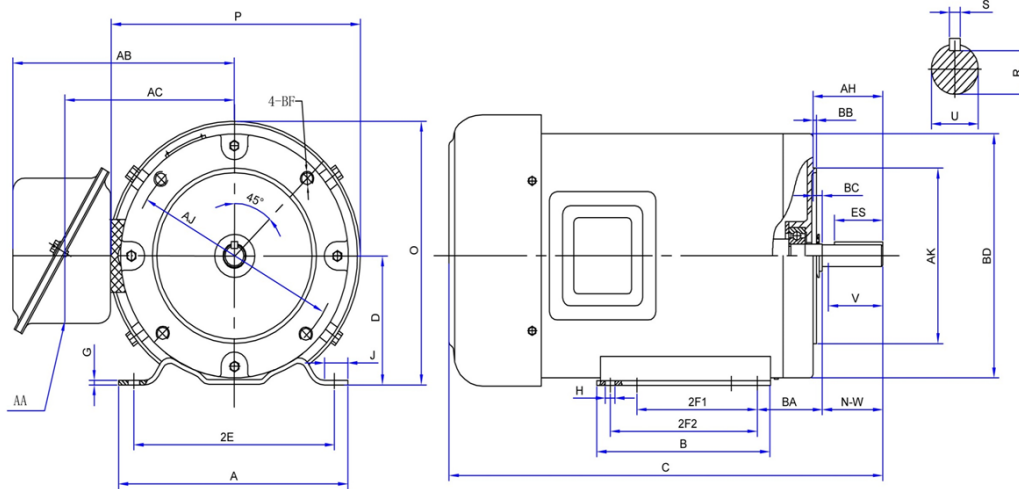

#### DIMENSIONS

HP	RPM	Frame	MOUNTING														
			A	B	C	D	G	H	J	E	2E	2F1	2F2	O	P	T	BA
3/4	3600	56C	6.30	3.94	11.80	3.50	0.12	0.35	1.46	2.44	4.88	3.00	NA	7.00	6.97	NA	2.75

FLANGE							Shaft Extension, Key Set					
AH	AJ	AK	BB	BC	BD	BF	U	V	R	S	ES	N-W
2.07	5.875	4.50	0.16	-0.19	6.50	3/8-16UNC	0.625	1.50	0.517	0.188	1.38	1.88

Conduit Box		Bearings		Mount
AA	AB	DE	ODE	
0.80	6.30	6203	6203	

**BEARING LUBRICATION:** The bearings come lubricated with Mobile Polyrex EM Polyurea Grease.



**ElectricalHelper.org**

For All Your Electric Needs Since 1928  
 411 N Platte Ave. York, NE. 68467

**AC-DC MOTORS :: SALES & SERVICE**  
**REWINDING :: CUSTOM CONTROL PANEL**

Kelly MacMillan

Office PH: 888.226.4917 Ext. 102

Fax: 888.226.4917

Cell: 402.679.1579

E-Mail: [kelly@electricalhelper.com](mailto:kelly@electricalhelper.com)



## F56C3/4M2D

**GENERAL PURPOSE ELECTRIC MOTOR  
HIGH EFFICIENCY / EISA COMPLIANT  
TOTALLY ENCLOSED FAN COOLED  
ROLLED STEEL CONSTRUCTION  
INVERTER RATED (10:1 VT; 5:1 CT)**

### PERFORMANCE DATA

HP	RPM	Frame	Voltage	Frequency (Hz)	Full Load S.F.	Insulation Class	NEMA Design	Slip (%)	NEMA Code	Enclosure Type	IP Rating	Max. Ambient
3/4	0	56C	575	60HZ	1.15	F	B	0	0	TEFC	IP44	40°C

Amps (460V)		Efficiency (%)			Power Factor			Torque (ft-lb)			DE Bearing	ODE Bearing	Connection	Weight (lbs.)	
FLA	LRA	100%	75%	50%	100%	75%	50%	FLT	LRT %	BDT %					
0	0	0.0	0	0	0	0.00	0	0.00	0	0	0	0	0	3 Lead	0

### NAME PLATE

MODEL		HP	RPM	FRAME
F56C3/4M2D		3/4	0	56C
VOLT		AMPS	S.F.	DESIGN
575		0	1.15	B
S.F. AMPS		CLASS	CODE	LBS
0		F	0	0
DE BEARING				
ODE BEARING				
0				
RATING CONT		MAX AMB.		
		40°C		
SER				

#### APPLICATIONS:

General purpose use on pumps, fans, blowers, compressors, conveyors, material handling and other industrial machinery installed in damp, dusty or dirty environments.



**ElectricalHelper.org**

For All Your Electric Needs Since 1928  
411 N Platte Ave. York, NE. 68467

**AC-DC MOTORS :: SALES & SERVICE  
REWINDING :: CUSTOM CONTROL PANEL**

**Kelly MacMillan**

**Office PH: 888.226.4917 Ext. 102**

**Fax: 888.226.4917**

**Cell: 402.679.1579**

**E-Mail: [kelly@electricalhelper.com](mailto:kelly@electricalhelper.com)**